

## Cortex HF50 Series Hybrid Heavy Fuel Engine



Engine Type:	Air-cooled 2-stroke hybrid
Fuel Type:	Heavy Fuel   UMAN-VP4F
Displacement:	50cc
Typical Weight:	4.7kg (10.4 lb)
	Engine, generator, exhaust & cooling system 3721g
	Isolation Mount 208g
	ECU and Triplex Pump 318g
	Hybrid Transmuter 431g
Power Output	2.4kW at 7500RPM
Fuel Consumption	500 g/kW-hr (0.8 lb/HP-hr) at 5000 RPM & 50% throttle

### Description

The Cortex HF50 Series Hybrid is a newly developed two-stroke hybrid heavy fuel UAV engine system from Currawong Engineering.

Based on the industry proven Currawong Corvid-50, the Cortex HF50 is a heavy fuel engine with hybrid power capability. The Cortex HF50 Series Hybrid is suitable as a replacement for batteries, gasoline engine or existing hybrid power systems for UAV platforms with electrically driven motors such as multi-rotors.

The hybrid architecture of the system allows for bidirectional power flow between the electrical system and the engine. During normal operation the engine can provide power to onboard electrical systems and charge batteries while providing prop power for flight. This allows for lower battery weight and better aircraft range. Power can also be directed from the battery system to the engine for self-starting, power boost during flight and in-air engine restart.

### Features

- Based on the proven reliability of the Currawong Corvid-50 engine.
- Full EFI suite including automotive-quality ECU processor, triplex high pressure fuel pump, ignition, sensors, injector and custom intake.
- ICE integrated with hybrid motor-generator provides battery replacement option for electric prop multi-rotor aircraft.
- Hybrid engine capability allows for a reduction in battery requirements and as a result improved range and reduced system weight.
- The hybrid system generator provides integrated avionics power.
- Hybrid architecture allows bidirectional power flow through the motor/generator, power can be sent from the engine to the electrical system or from the batteries to the engine for power boost or in-air restart.

**The Corvid-50 Parallel Hybrid engine package includes:**

- Currawong three-bearing crank case
- Desert Aircraft DA50 cylinder and piston
- Currawong induction system with manifold and throttle body
- CDI ignition system
- Miniature engine control unit (ECU)
- Currawong Triplex high pressure fuel pump
- Automotive grade fuel injector
- Crank sensor
- Integrated isolation mount
- Low noise exhaust
- T-motor U13II motor-generator
- Detailed operation & service manual and interface control document
- Manifold and cylinder head temperature sensors
- Currawong Hybrid Transmuter

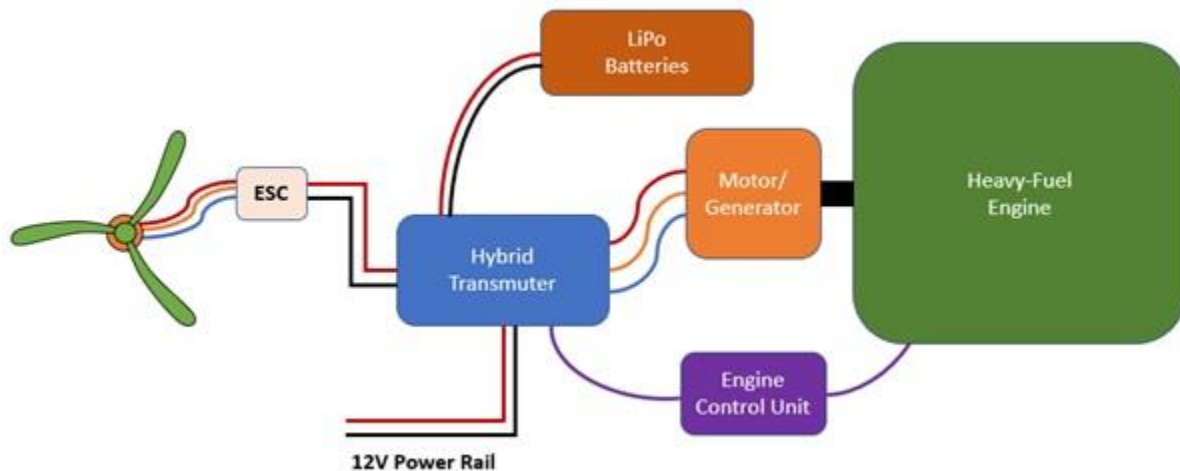
**Hybrid System Architecture**

The hybrid architecture of the system allows for bidirectional power flow between the electrical system and the engine.

During normal operation system power is supplied by the heavy-fuel engine which provides power to onboard electrical systems, charging batteries and powers electric prop motors for flight. In this case no additional power is drawn from the batteries.

However, power can be directed from the battery system to the engine for self-starting or for in-air engine restart. The transmuter can provide instantaneous additional power from the batteries to the ESCs if prop loading exceeds the power capability of the heavy fuel engine for short periods of time. This allows for a power-boost for take-off or short-term sprint.

The Currawong Cortex HF50 consists of the following major components:

## Heavy Fuel Engine

50cc engine based on the Corvid-50 modified and calibrated to run UMAN-VP4F heavy fuel.

The core engine comprises the engine cylinder head, crankcase and internal components including the piston assembly. Other systems considered part of the core engine include:

- Ignition unit
- Spark plug
- Fuel injector
- Crank sensor
- Throttle servo
- Temperature sensors including Cylinder Head Temperature (CHT) and Manifold Air Temperature (MAT)
- Manifold Pressure Sensor
- Throttle Body and Manifold
- Exhaust
- Cooling duct and cooling control servo

## Motor/Generator

The motor/generator in the Cortex HF50 Series Hybrid is a T-Motor U13II 130 KV.

The T-Motor acts as both a motor for starting the engine or power-boosting the engine (converting electrical power into mechanical power) as well as a generator (converting mechanical power into electrical power).

The motor used on the Currawong hybrid is frameless and is fitted with hall sensors by Currawong for monitoring motor position to ensure correct commutation.



## Hybrid Transmuter

The Currawong designed Hybrid Transmuter maintains a balance of energy flow through the system, managing battery charging and the changing load requirements of the UAV determining whether to deliver power from the engine to the batteries or from the batteries to the engine.



Based on the high power, high reliability Currawong Velocity ESC the Currawong Hybrid Transmuter provides the same unmatched level of robustness, testing and traceability.

Voltage	60V/14S
Current (Sustained/Peak)	150A/300A
Power	7.5kW
Operating Temperature	-20°C – 100°C

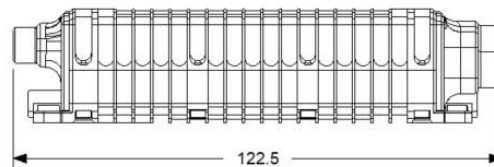
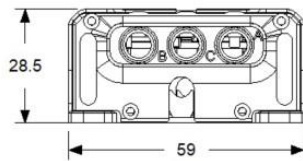
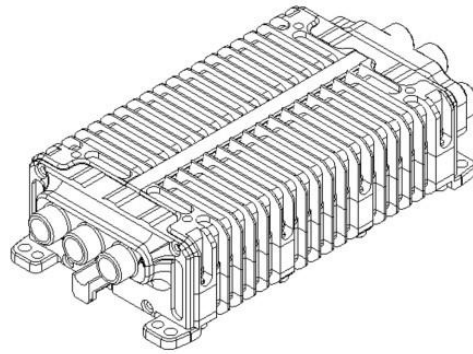

### Engine Control Unit

Designed by Currawong Engineering, the ECU:

- Precisely controls fuel delivery and spark advance.
- Automatic altitude compensation.
- Engine temperature regulation.
- Throttle control.

Engine control functionality is based on the Autronic ECU software, which has been proven in operation over many years and thousands of vehicles.

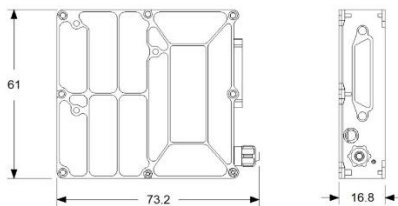
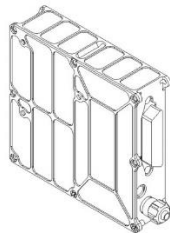

## Triplex Pump

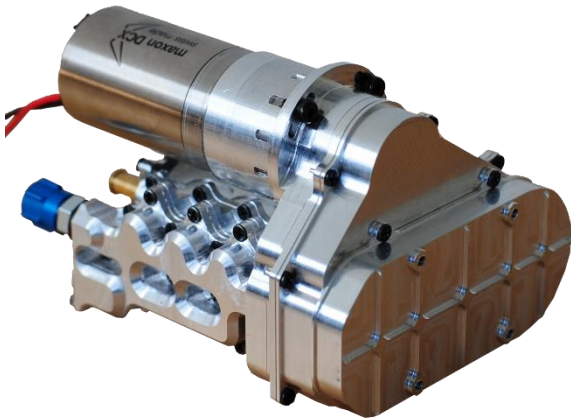

In order to suitably atomise UMAN-VP4F heavy fuel the Cortex-50 engine makes use of the Currawong designed Triplex pump.

The Triplex fuel pump's unique three piston design provides high pressure, smooth fuel delivery and a tightly integrated control system allows for precise regulation of fuel delivery.

The Triplex pump is self-priming and capable of metering fuel flow with <math><1\%</math> error.

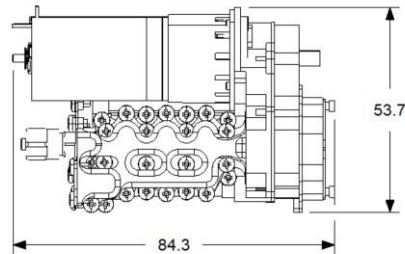
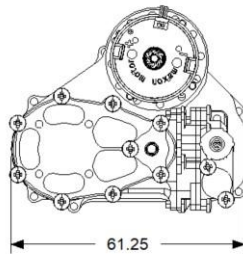
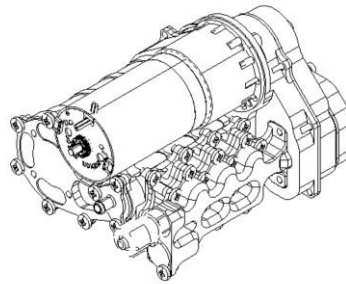

## Heavy Fuel

During development of the Cortex HF50 significant research and development time was dedicated to the use of an innovative fuel. The result was the selection of the Isopar based UMAN-VP4F developed by VP Racing.

Spark ignited heavy fuel engines for UAVs commonly operate on fuels such as JP-5 and JP-8. These kerosene-based fuels are excellent for gas-turbine engines which have no octane requirement but are not as ideal in piston engines where octane becomes important. The experience of Currawong Engineering has been that spark ignited engines running these fuels have incomplete combustion leading to deposit build up. This leads to the need for more frequent maintenance and lower mean time between overhauls. These fuels also have significant handling risks.

Through research Currawong discovered previous investigations into the use of Isopar as an alternative fuel for gasoline powered engines. Isopar maintains the benefit of a high-octane level while providing a high flash point, an important safety consideration and one of the primary benefits of heavy fuel. It also has lower risks for handling and is essentially odourless making it much more pleasant for operators.

Understanding customers' requirements for logistical certainty in any fuel supply and confidence in the consistency of the fuel Currawong entered discussions with VP Racing Fuels, a US based high performance fuel company with global distribution, about supply of an Isopar based fuel. VP have developed UMAN-VP4F based on Isopar but treated with aromatics and additives and tested and controlled to the same level as their high-performance racing fuels.

Currawong has shown that UMAN-VP4F works well as a spark-ignited fuel in the Corvid-50 engine and burns with very clean combustion. Power output of the engine has been comparable to that of petrol.

UMAN-VP4F requires 8 to 10 bar of fuel pressure, ideal for the use of Currawong's specialist Triplex fuel pump.

The table below summarises common fuels, highlighting their suitability for UAV operations in a spark-ignited piston engine.

<b>Fuel Type</b>	<b>Flash Point (°C)</b>	<b>Octane Rating</b>
<b>Petrol</b>	-43	93
<b>Diesel</b>	38	15 - 25
<b>JP-8</b>	38	15
<b>JP-5</b>	60	15
<b>UMAN-VP4F</b>	63	87

The Cortex HF50 has been designed and calibrated to run on VP UMAN-VP4F and it is Currawong's recommended fuel for the engine.

**Basic Dimensions**

Basic engine envelope dimensions:

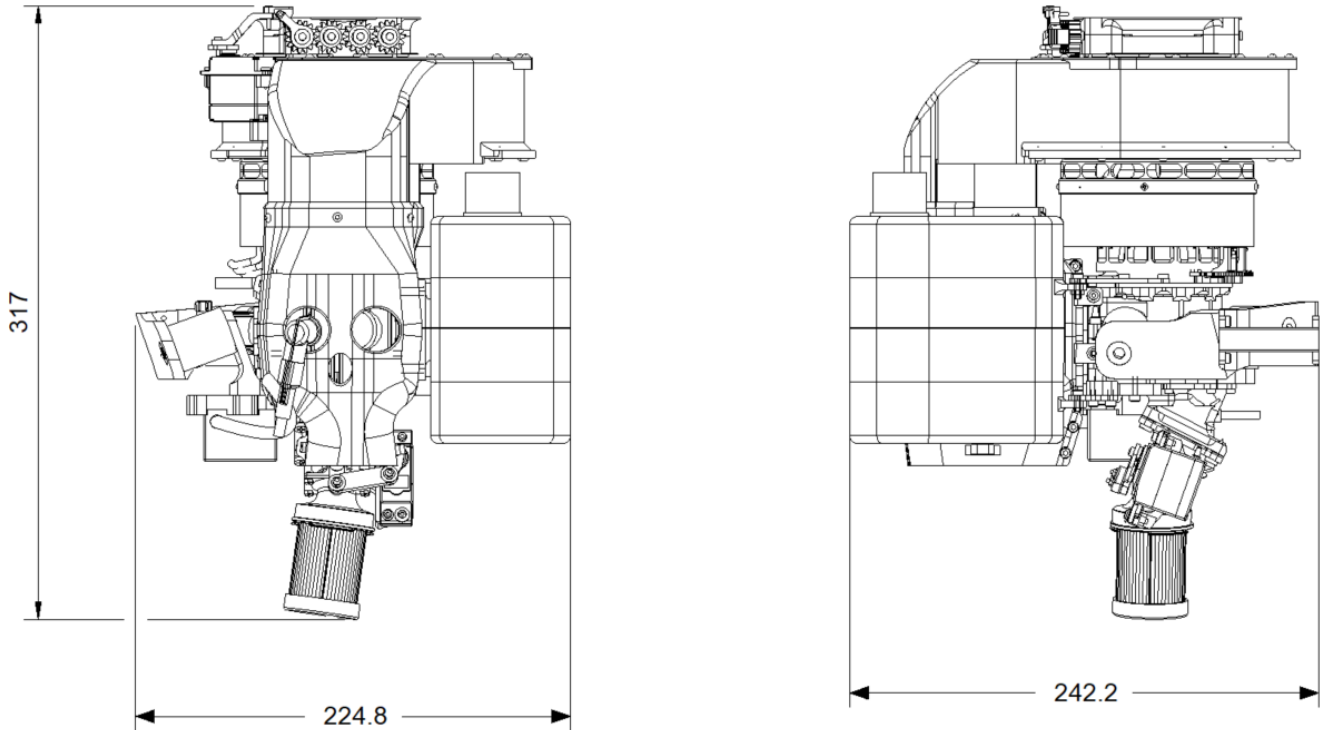

Isolation mount dimensions:

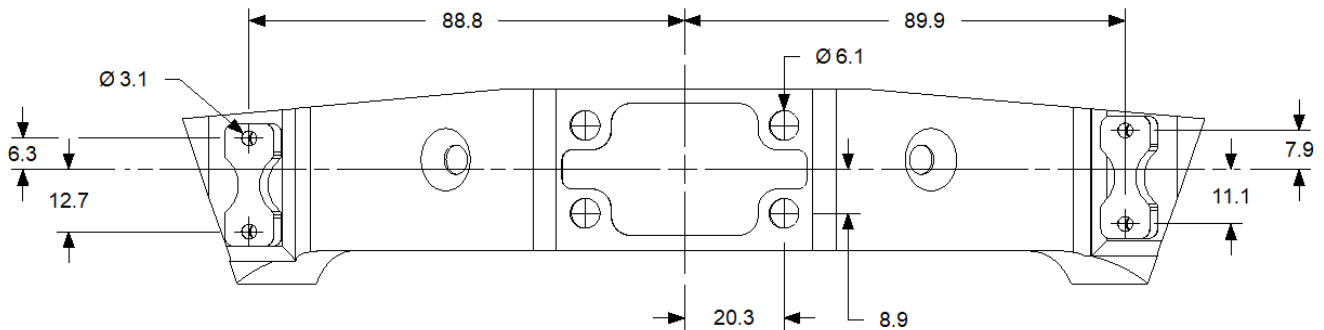

### Engine Performance

The power curves below indicate the typical generated electrical power from the Cortex HF50 Series Hybrid. This does not include additional power boost available from the battery system depending on battery selection. For example, a 5 Ah 30C 14S battery system can supply up to an additional 8kW of instantaneous power.

